

MAIN DIMENSIONS

REVISION

Muutos

Pvm

AUTHOR

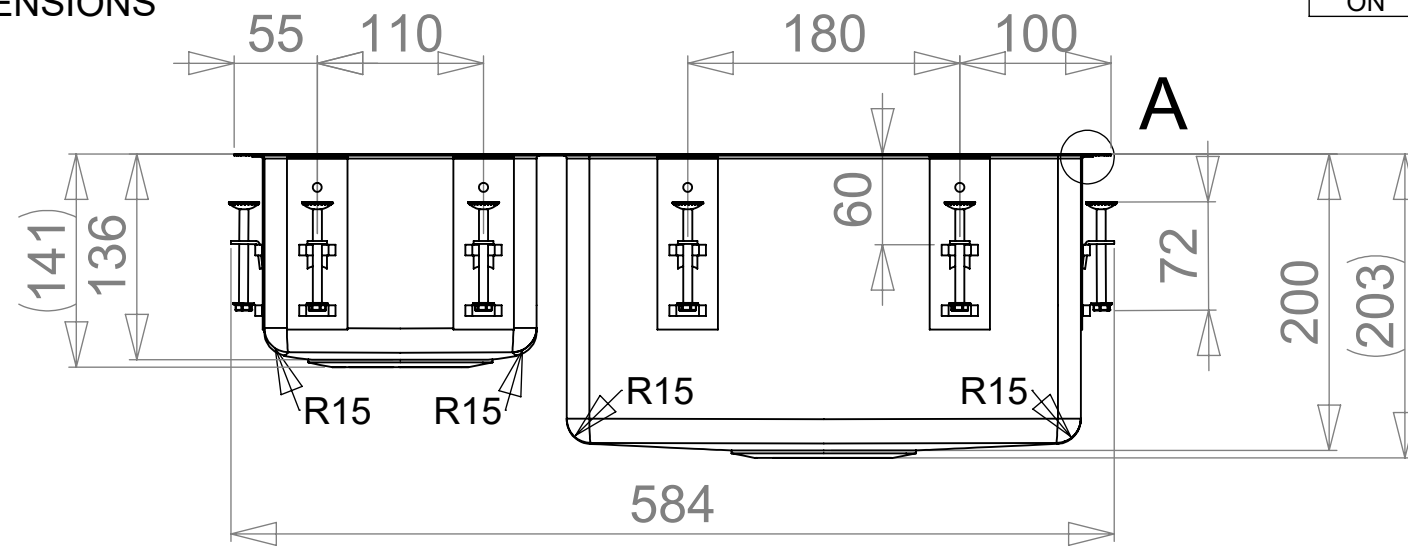

Mono edge  
A (2 : 1)

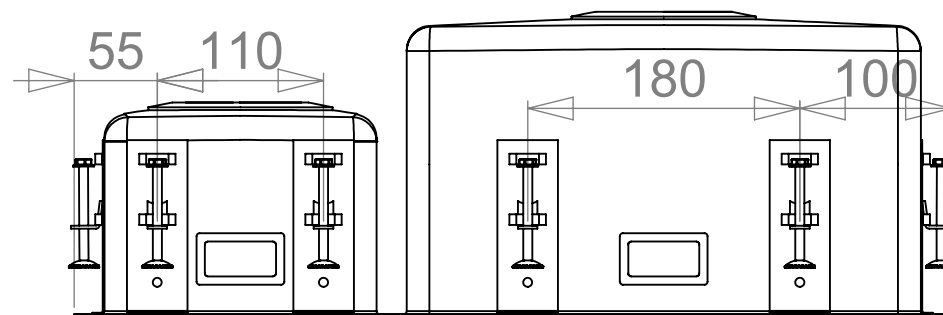
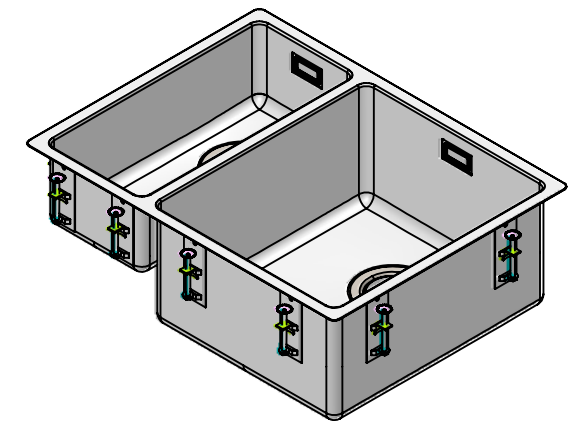
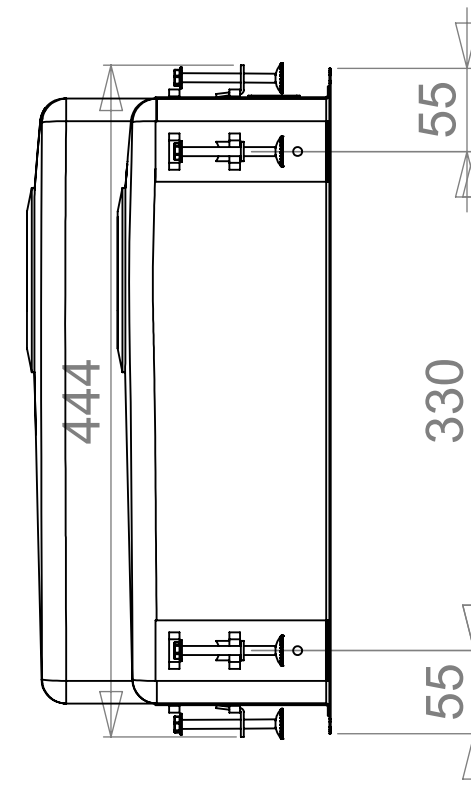
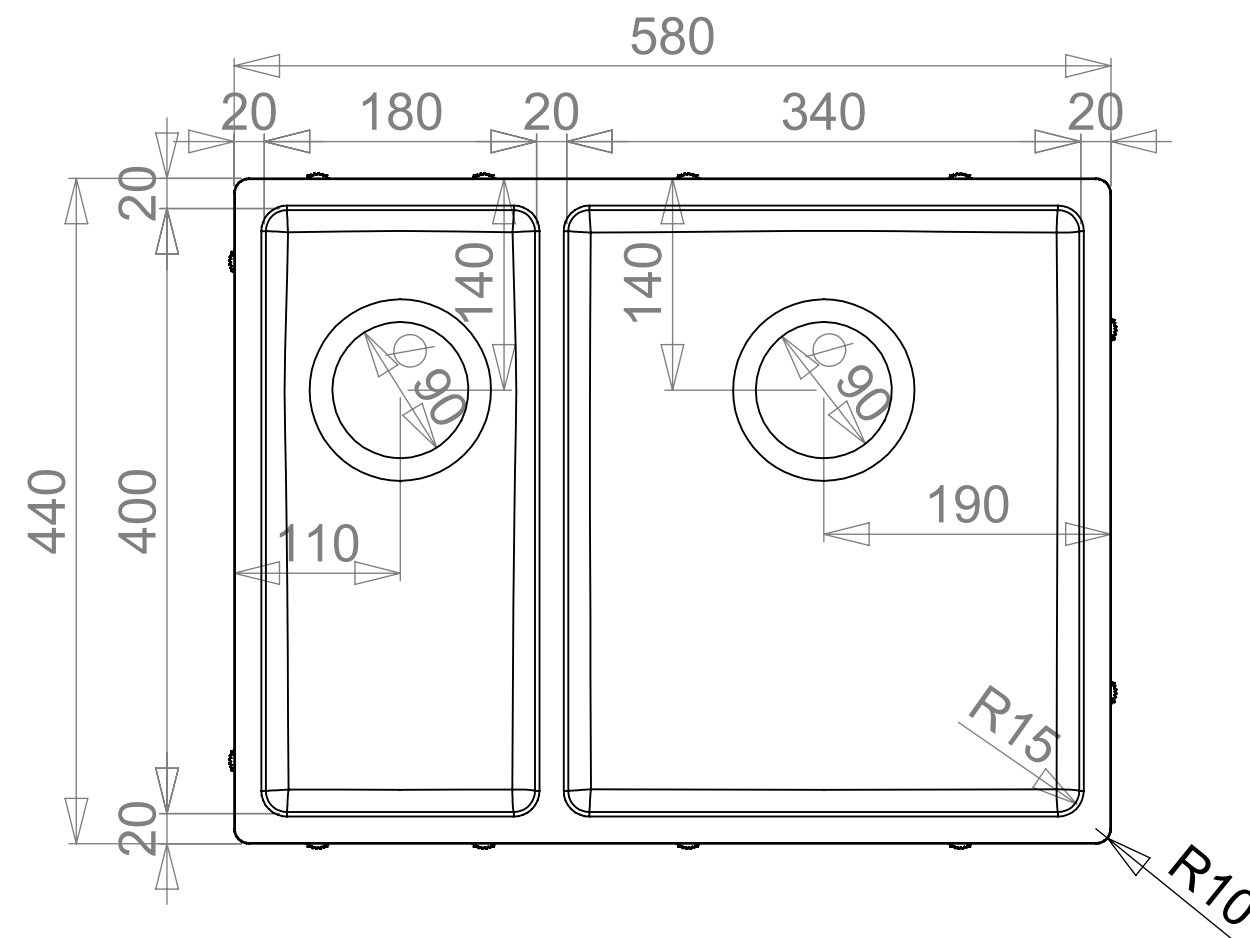
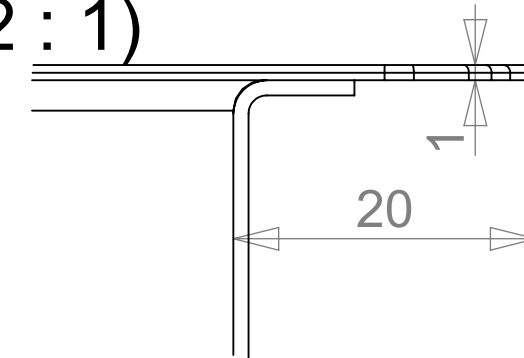

	Massa	kg	Yleistoleranssi	Suunnittelija	Pvm
	Mittakaava	1:5	Nimike	VS	08.02.2019
 www.stala.com			Nimitys	Tarkastaja	Pvm
			LAGOM-18-34	Piirustusnumero	Sivu
			Technical Data Sheet	18188	1/6
					Rev
					--08

WORKTOP ASSEMBLY

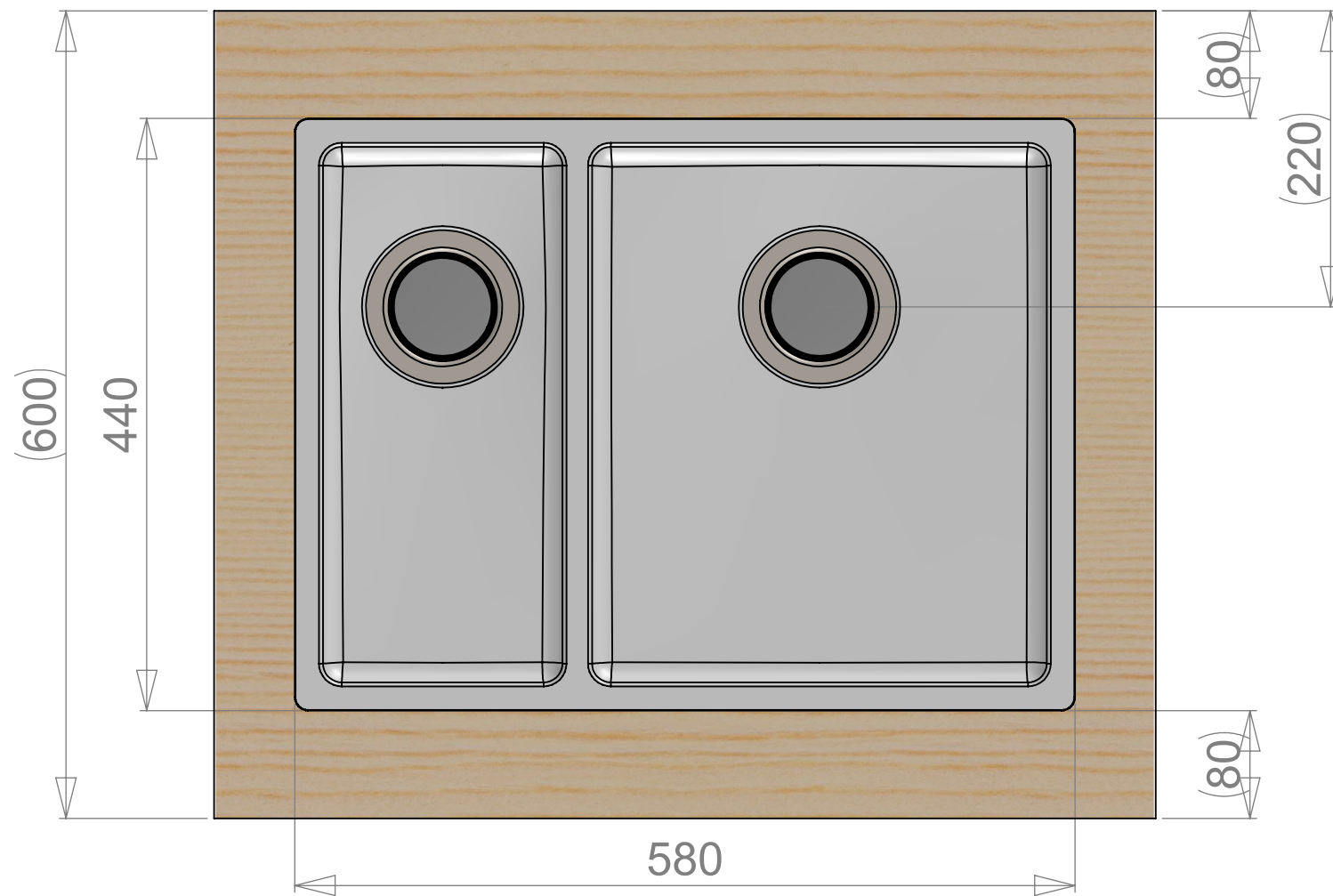

	Massa	Yleistoleranssi	Suunnittelija	Pvm
	kg		VS	08.02.2019
	Mittakaava	Nimike	Tarkastaja	Pvm
	A3 1:5			
 www.stala.com	Nimitys	Piirustusnumero	Sivu	
	LAGOM-18-34	18188	2/6	
	Technical Data Sheet		Rev	--08

SPACE REQUIREMENTS

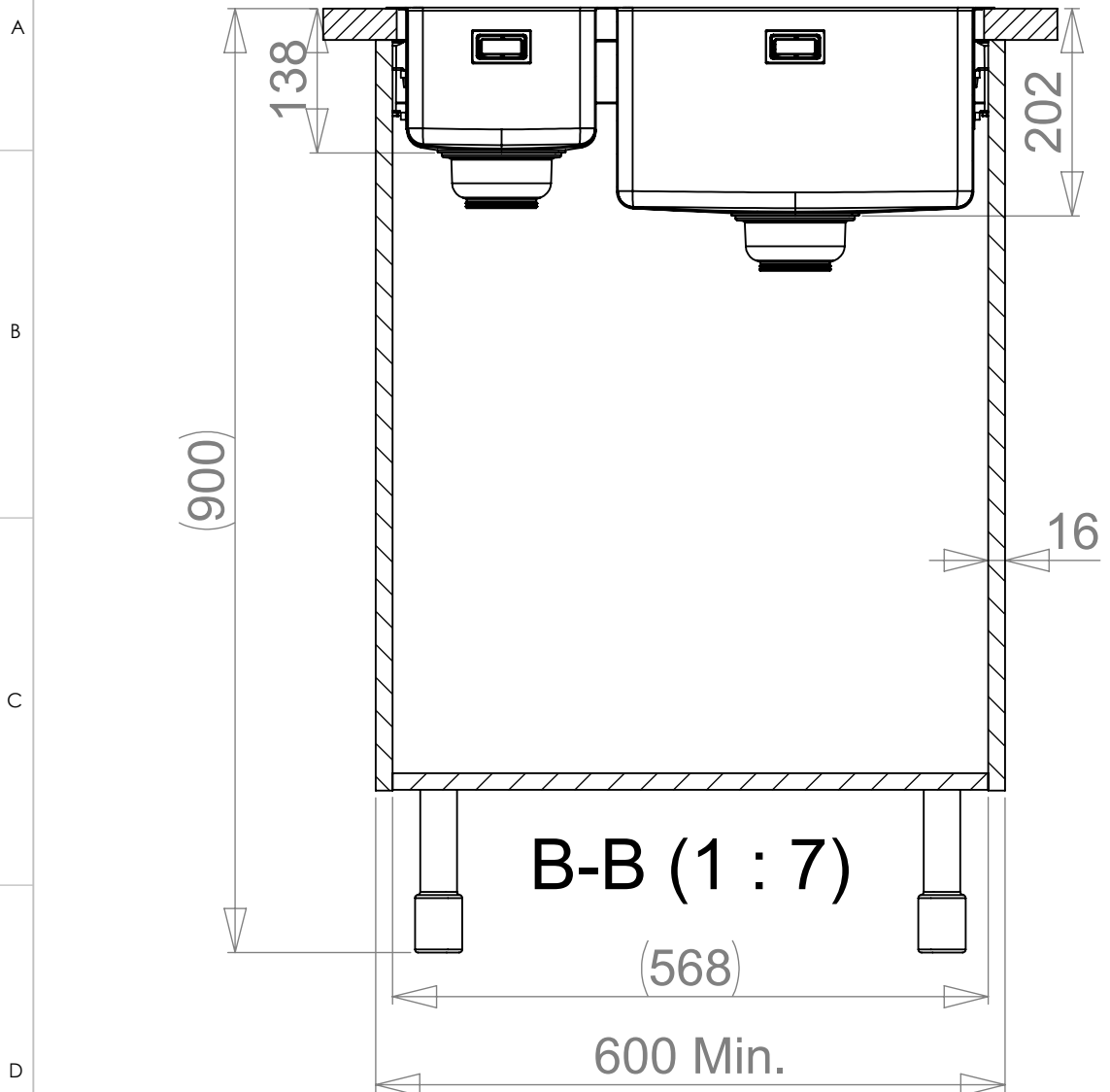

B-B (1 : 7)

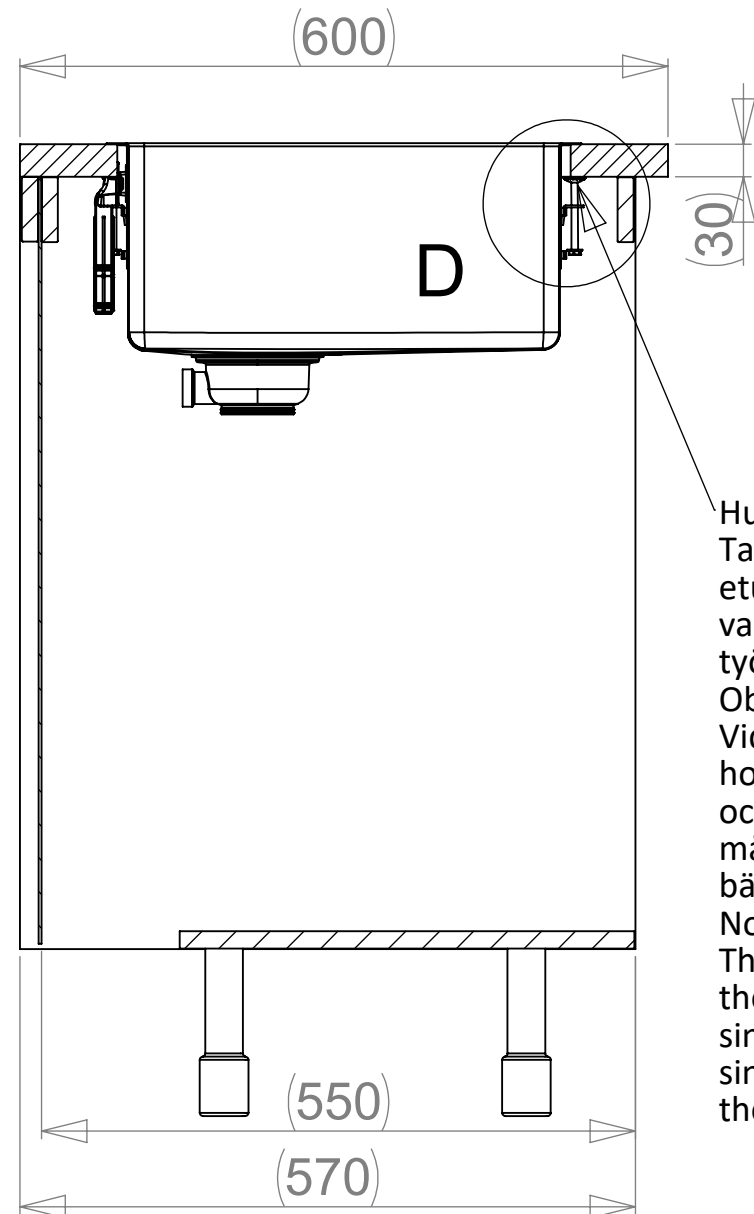

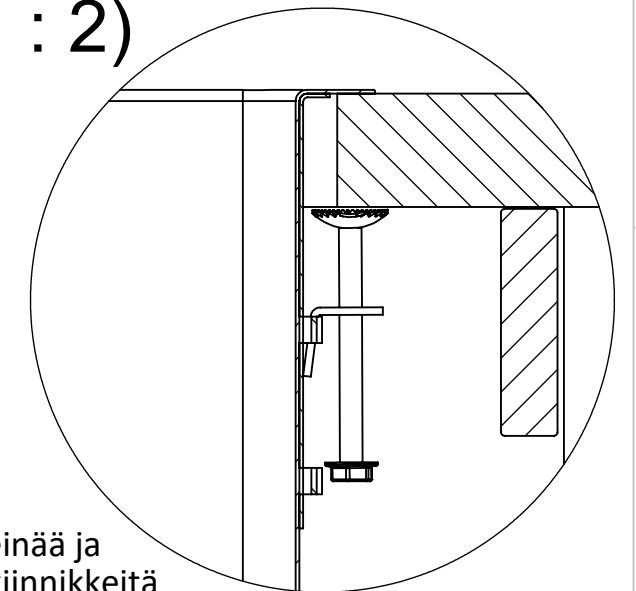

C-C (1 : 7)

D (1 : 2)

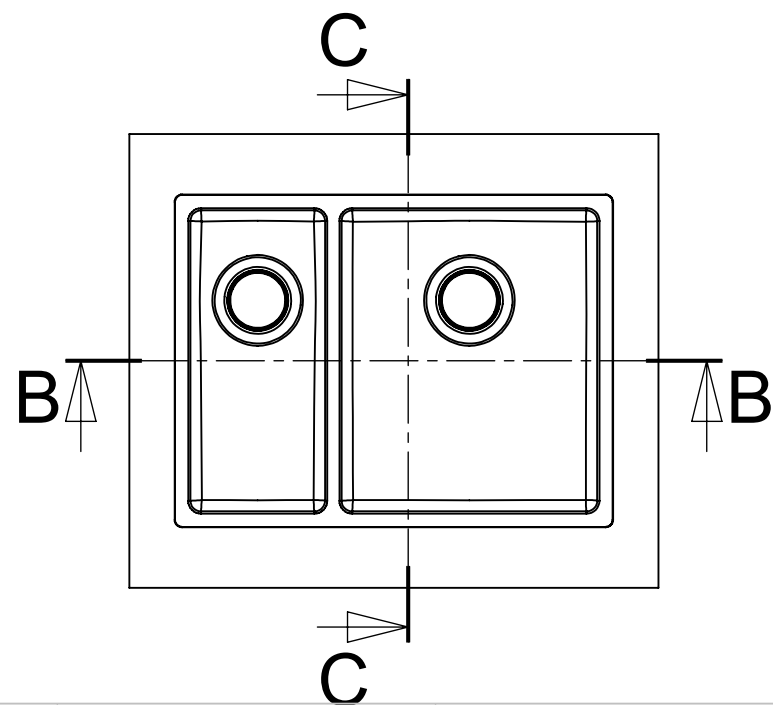
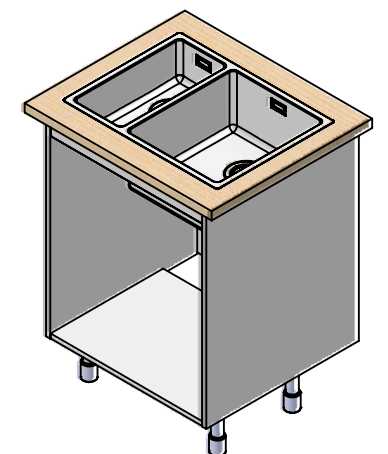

Huom!  
 Tarvittaessa kaapin väliseinää ja etu/takalistaa lovetettava kiinnikkeitä varten ja pesuallas on kiinnitettävä ennen työtason asennusta.  
 Obs!  
 Vid behov måste en inskärning för hofästena göras i skåpets mellanvägg och förbindningslist och diskbänken måste fästas innan du monterar bänkskivan.  
 Notice!  
 The partition walls and front/back list of the cupboard must be notched for the sink mountings when needed and the sink must be fastened before installing the worktop.



 www.stala.com	Massa kg	Yleistoleranssi	Suunnittelija VS	Pvm 08.02.2019
	Mittakaava A3 1:10	Nimitys	Tarkastaja	Pvm
LAGOM-18-34 Technical Data Sheet		Piirustusnumero 18188	Sivu 3/6	Rev --08

CUT-OUT

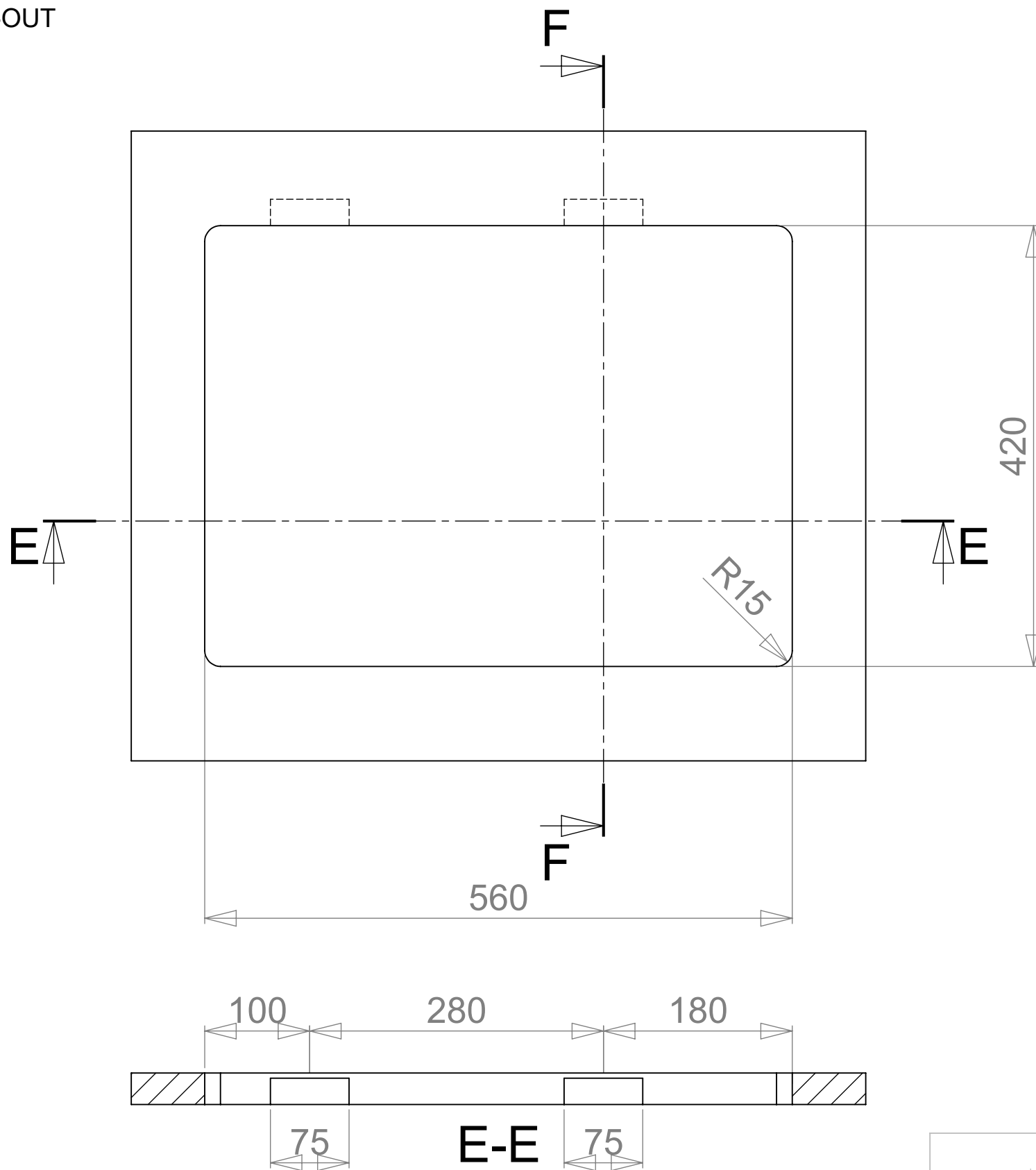

Cut-out for overflow

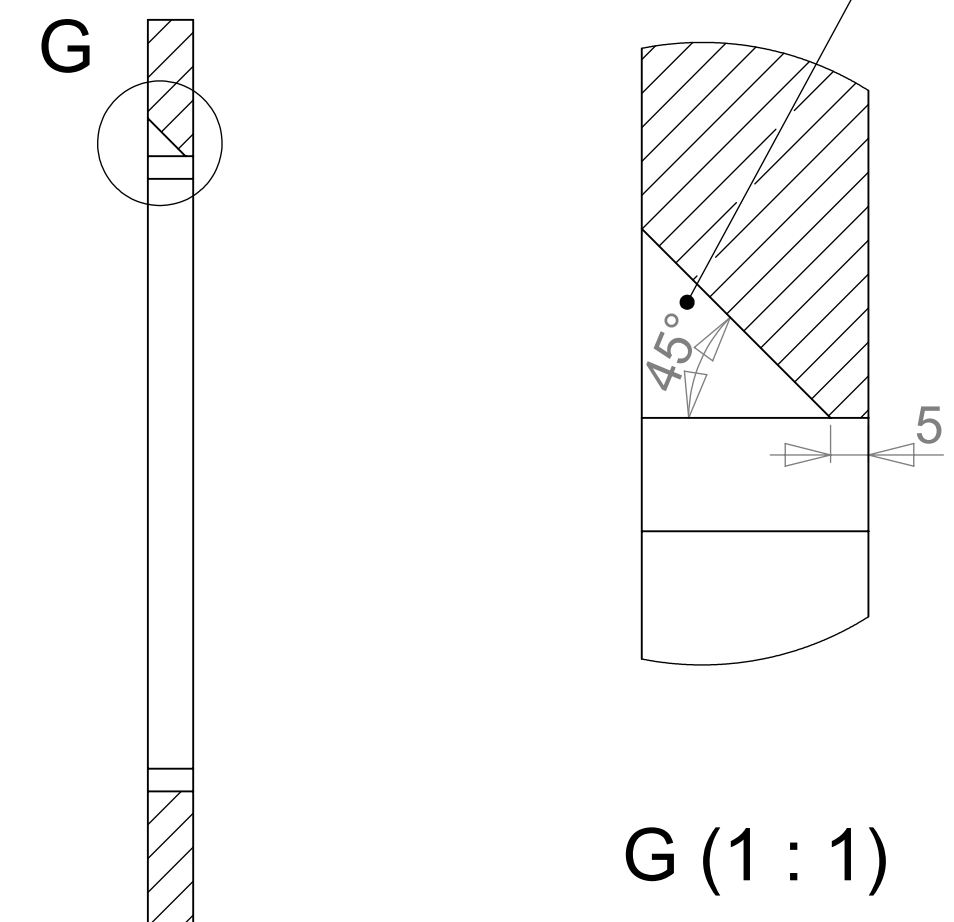

G (1 : 1)

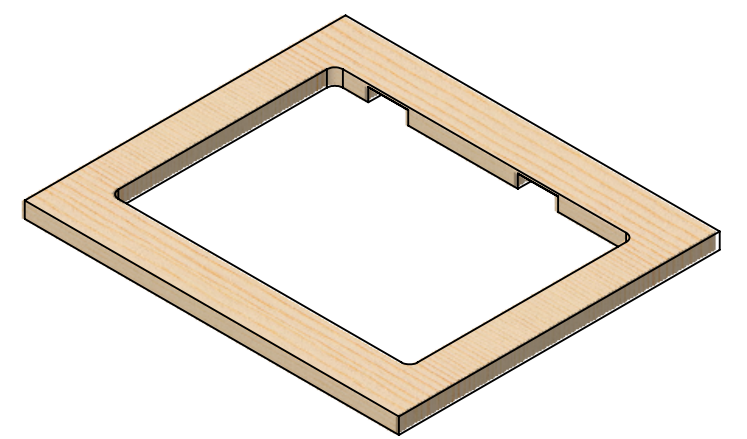

F-F

	Massa	Yleistoleranssi	Suunnittelija	Pvm
	kg		VS	08.02.2019
	Mittakaava	Nimike	Tarkastaja	Pvm
	A3	1:5		
	Nimitys	Piirustusnumero	Sivu	
	LAGOM-18-34	18188	4/6	
Technical Data Sheet			Rev	--08

